

OAC-210

Open Air Cooler

User Manual

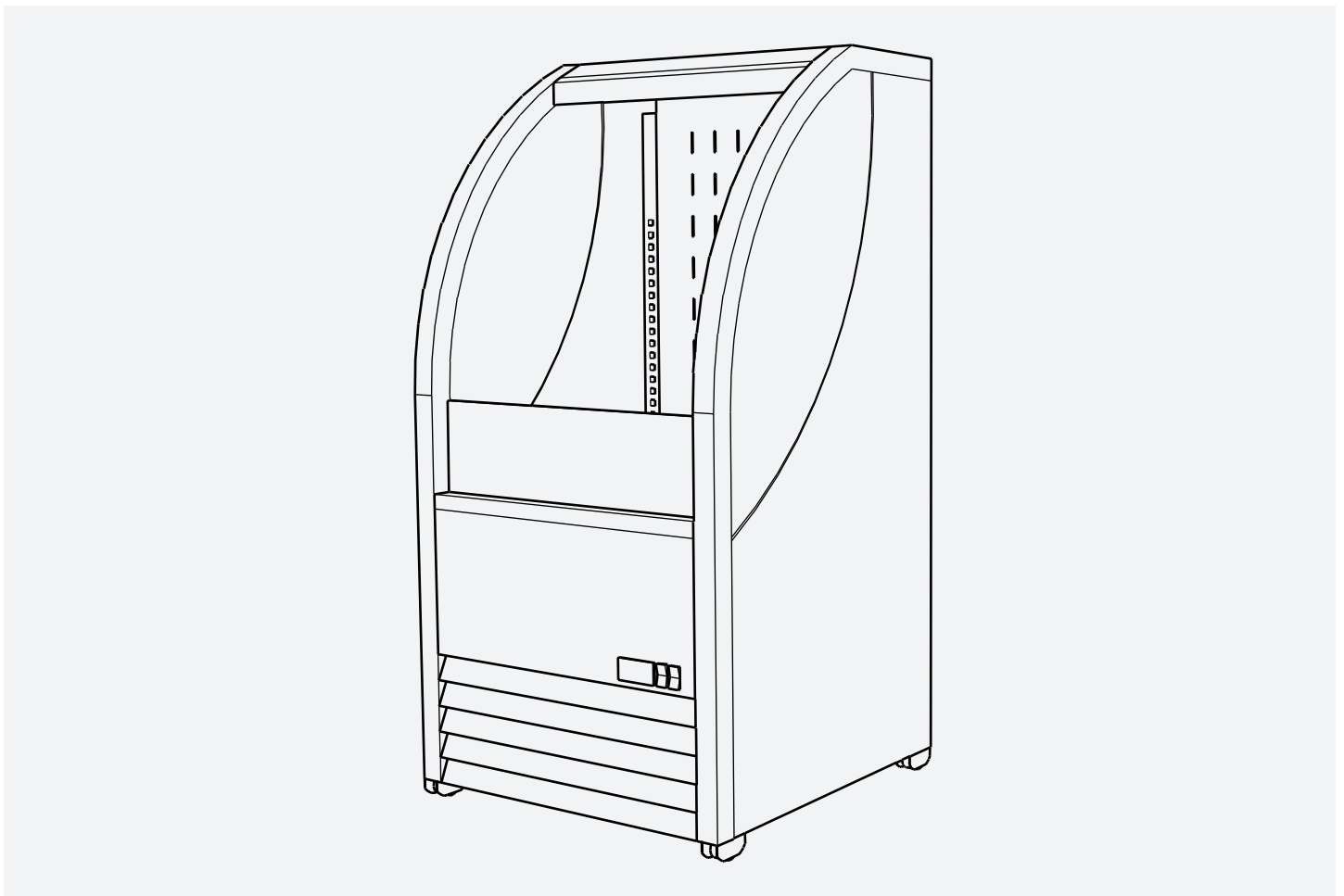

Office: 1.888.685.9959
Tech Support: 1.888.685.8324
www.mtlcool.com

7880 Boul. Industriel,
Chambly, Quebec
J3L 4X3

 **MTLCOOL**
REFRIGERATED P.O.P. DISPLAY SOLUTIONS

TABLE OF CONTENTS

UNPACK AND INSPECTION	1
SAFETY AND PRECAUTIONS	2
PROPER DISPOSAL OF THE REFRIGERATOR	2
REFRIGERANT DISPOSAL	2
HOW TO CONNECT ELECTRICITY	2
SAFETY PRECAUTIONS	2
MAINTENANCE	3
INSTALLATION	4
INSTALLATION REQUIREMENTS	4
ELECTRICAL REQUIREMENTS	4
CONTROLLER OPERATION	5
OAC-210 BEST PRACTICES	6
WARRANTY INFORMATION	7



UNPACK & INSPECTION

All MTL Cool equipment is packaged in a manner to prevent from damage in transport and for the unit to remain visible for a visual inspection. Equipment is palletized, shrink wrapped and sometimes boxed.

WARNING

At time of delivery, carefully examine the equipment for any damage that may have occurred in transit.

All damages should be noted on the bill of lading or delivery receipt.

The equipment should be unpacked as soon as possible. Verify that all equipment including internal components and glass were not damaged in transit.

If any damage is found please contact MTL Cool at **1-888-685-8324** immediately to report the damage. If possible please take pictures of the damage.



SAFETY & PRECAUTIONS

DANGER!
RISK OF CHILD ENDANGERMENT

PROPER DISPOSAL OF THE REFRIGERATOR

To avoid the possibility of child endangerment, please take the following precautions before throwing away the refrigerator:

- Leave the shelves in place so that children may not easily climb inside.
- Never allow children to operate, play with, or crawl inside the refrigerator.

REFRIGERANT DISPOSAL

All refrigeration products contain refrigerants, which under the Guidelines of Federal Law must be removed before disposal of product. It is the consumer's responsibility to comply with federal and local regulations when disposing of this product.

- Never clean refrigerator parts with flammable fluids. The fumes can create a fire hazard or explosion.
- **DO NOT** store or use gasoline or any other flammable vapors and liquids in the vicinity of this or any other refrigerator. The fumes can create a fire hazard or an explosion.

HOW TO CONNECT ELECTRICITY

This refrigerator should be properly grounded for your safety.

It is your responsibility and obligation to have the proper outlet installed. The power cord of this refrigerator is equipped with either three-prong plug (115v) 5-15P plug. **DO NOT**, under any circumstances, cut or remove the third ground prong from the power cord supplied.

The cord should be secured behind the refrigerator and

not left exposed or dangling to prevent accidental injury.

SAFETY PRECAUTIONS

Keep the unit upright during transportation. If the unit is tilted during transportation, please allow the unit to sit upright for a minimum of 2 hours before plugging in the unit.

Ensure that there is a minimum of 3 inch of space behind the unit for air circulation.

(A metal "spine" may be pre-installed on the rear of the cooler ensuring there is always space behind the cooler).

Place the cooler on a level surface.

Place the unit in a dry environment for optimal performance.

Do not obstruct the ventilation both at the bottom front and interior of the cooler.

Before using this freezer/refrigerator, it must be positioned and installed in accordance with the installation Instructions (see page 4).

DO NOT allow children to climb, hang or stand on the shelves in the freezer/refrigerator. Serious damage could be caused to both the children and the unit.

DO NOT touch the cold surfaces in the freezer compartment when hands are damp or wet. Skin may stick to these extremely cold surfaces.

Before cleaning or making any repairs, unplug the freezer/refrigerator.

Repair or replace immediately all power cords that have become frayed or otherwise damaged.

DO NOT place the cooling cabinet on top of the electrical plug.

DO NOT use an extension cord with this appliance. If the

power cord is too short, have a qualified electrician or service technician install an outlet near the appliance. Use of an extension cord can negatively affect the performance of the unit. The refrigerator should always be plugged into its own individual electrical circuit (unless specified otherwise), which has a voltage rating that matches the rating plate.

When removing the refrigerator from the wall, be careful not to roll over or damage the power cord.

MAINTENANCE

The cooler should be cleaned once a week with power supply disconnected. In cleaning, please use mild rinsing water or non-corrosive cleanser essence.

It is recommended that preventative maintenance be performed on the unit every 6 months.

This unit is covered by a 1 year limited warranty.



INSTALLATION

INSTALLATION REQUIREMENTS

❶ DO NOT place the cooler in a location with air drafts that could disrupt the air curtain

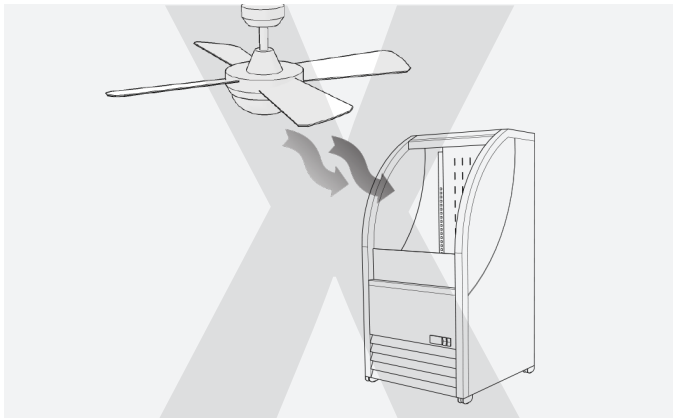

❷ There must be at least 2 inches of space behind the unit at all times to ensure proper air flow.

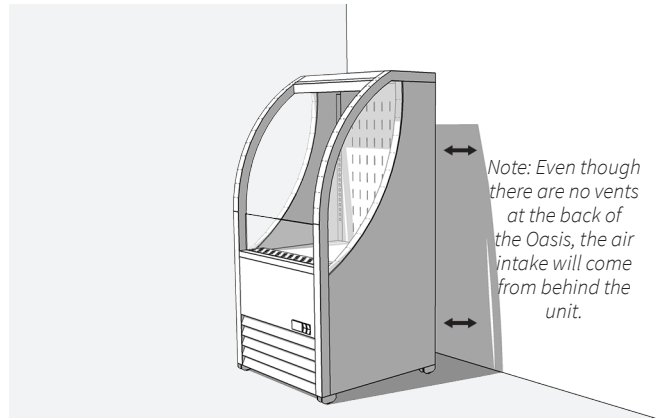

❸ DO NOT place the cooler in a location with ambient temperatures over 75°F or 50%RH

❹ Cooler should not be placed near other equipment that can be expelling heat. (example, Chicken warming stations)

ELECTRICAL REQUIREMENTS

- A dedicated power line from the breaker box
- 20 Amp Breaker
- The wire gauge should be sufficient to limit voltage drop under 15 amp load to 3%.

Please consult factory for voltage drop calculations based on line lengths, see below.

WIRE GAUGE FOR 3% VOLTAGE DROP IN SUPPLY CIRCUITS

Amps	20	30	40	50	60	70	80	90	100	120	140	160
2	14	14	14	14	14	14	14	14	14	14	14	14
3	14	14	14	14	14	14	14	14	14	14	14	14
4	14	14	14	14	14	14	14	14	14	14	14	12
5	14	14	14	14	14	14	14	14	14	12	10	10
5	14	14	14	14	14	14	14	14	14	12	10	10
7	14	14	14	14	14	12	12	12	10	10	10	8
8	14	14	14	14	12	12	12	10	10	10	8	8
9	14	14	14	12	12	12	10	10	10	8	8	8
10	14	14	14	12	12	12	10	10	10	8	8	8
12	14	14	12	12	10	10	10	8	8	8	8	6
14	14	14	12	10	10	10	8	8	8	6	6	6
16	14	14	12	10	10	8	8	8	8	6	6	6
18	14	12	10	10	8	8	8	8	8	8	8	5
20	14	12	10	10	8	8	8	6	6	6	5	5
25	12	10	10	8	8	6	6	6	6	5	4	4
30	12	10	8	8	6	6	6	6	5	4	4	3
35	10	10	8	6	6	6	5	5	4	4	3	2
40	10	8	8	6	6	5	5	4	4	3	2	2
45	10	8	6	6	6	5	4	4	3	3	2	1
50	10	8	6	6	5	4	4	3	3	2	1	1

CONTROLLER OPERATION MODEL: CAREL PJEZ

AN ACCESS CODE IS NEEDED TO MODIFY PARAMETERS.
PLEASE CONTACT **MTL TECH SUPPORT** TO RECEIVE YOUR
ACCESS CODE **1.888.685.8324**

DISPLAYS AND FUNCTIONS

During normal operation, the controller displays the temperature read by probe 1. In addition, the display has LEDs that indicate the activation of control functions (see Table 1), while the 3 buttons can be used to activate / deactivate some of the functions (see Table 2).

LEDS AND ASSOCIATED FUNCTIONS

icon	function	normal operation			start up
		ON	OFF	blink	
	compressor	on	off	request	ON
	fan	on	off	request	ON
	defrost	on	off	request	ON
	alarm	all	no alarm	-	ON

Tab. 1

TABLE OF FUNCTION ACTIVATED BY THE BUTTONS

button	normal operation		start up
	pressing the button alone	pressed together	
	more than 3 s: toggle ON/OFF	Pressed together start/stop continuous cycle	-
	more than 3 s: start/stop defrost		for 1 s display firmware vers. code
	- 1 s.: display/set the setpoint - more than 3 s: access parameter setting menu (enter password '22') - mute audible alarm (buzzer)	-	for 1 s RESET current EZY set

Tab. 2

TURNING THE DEVICE ON/OFF

Press UP for more than 3 seconds. The control and defrost algorithms are now disabled and the instrument displays the message "OFF" alternating by temperature read by the set probe. Manual

SETTING THE SET POINT (DESIRED TEMPERATURE)

Step	Action	Effect	Meaning
1	Keep SET button pressed for 2 s	After 1 sec currently setpoint value will flash on display	It's regulation setpoint currently active
2	Press UP or DOWN buttons	Setpoint value will change	Set desired value
3	Press SET button	Controller will visualize temperature read by probes again	Setpoint is modified and saved

Tab. 3

ACCESSING AND SETTING THE PARAMETERS

Step	Action	Effect	Meaning
1	Keep SET button pressed for 3 s	After 3 sec display will visualize " PS "	Password is requested
2	Press SET button again	Display will visualize " 0 " blinking	
3	Press UP or DOWN button	Visualized value on display will change	Insert password " 22 "
4	Press SET button	After 5 sec the first parameter, " /5", will be visualized on display	It's the name of the first parameter
5	Press UP or DOWN button	Parameter list will be scrolled on display (refer to Table of parameters)	Select desired parameter
6	Press SET button	Display will visualize value of the selected parameter	It's the currently parameter value
7	Press UP or DOWN button	Parameter value visualized on display will change	Set desired value
8	Press SET button	Display will visualize parameter name again	Attention : parameters updating is not yet active
9	Repeat steps 5, 6, 7 and 8 for all desired parameters		
10	Keep SET button pressed for 5 s	Controller will visualize temperature read by probes again	Attention: now parameters updating will be active

Tab. 4

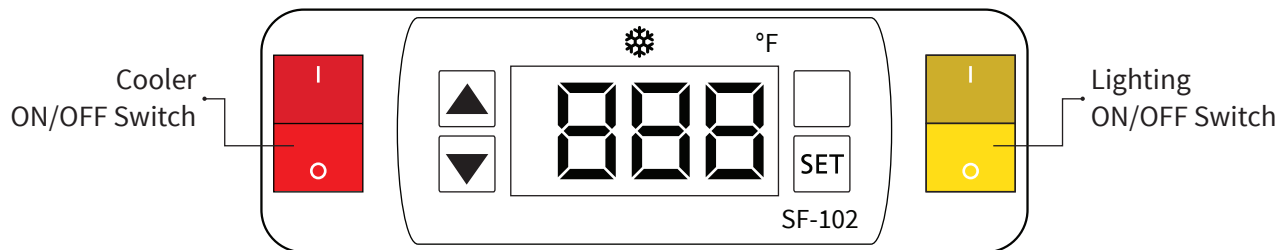

OAC-210 COOLER

BEST PRACTICES

SAFETY & PRECAUTION

- Use this appliance for its intended purpose as described in this Owner Manual.
- Keep the cooler upright during transportation. If the unit is tilted during transportation, please allow the unit to sit upright for a minimum of 2 hours before plugging in the unit.
- Ensure that there is a minimum of 3 inch of space behind the unit for air circulation.
- Place the cooler on a level surface.
- Place the unit in a dry environment for optimal performance.
- Do not obstruct the ventilation both at the bottom front and interior of the cooler.
- **DO NOT** allow children to climb, hang or stand on the shelves in the unit. Serious damage or injury could occur.
- Before cleaning or making any repairs, unplug the refrigerator.
- When moving the refrigerator, be careful not to roll over or damage the power cord.
- **DO NOT** use a cord that shows cracks or abrasion damage along its length or at either end.
- Repair or replace immediately all power cords that have become frayed or otherwise damaged.
- **DO NOT** place the cooling cabinet on top of the electrical plug.
- **DO NOT** position the cooler near any heat sources.
- **DO NOT** unplug the refrigerator by pulling the power cord. Always grip the plug firmly and pull straight out from the receptacle.
- **DO NOT** use an extension cord with this appliance. If the power cord is too short, have a qualified electrician or service technician install an outlet near the appliance. Use of an extension cord can negatively affect the performance of the unit. The refrigerator should always be plugged into it's own individual electrical circuit (unless specified otherwise), which has a voltage rating that matches the rating plate.

PREVENTATIVE MAINTENANCE

Ensure preventative maintenance is being performed on a regular basis (every 3-4 months). Preventative maintenance includes:

- **Cleaning condenser coil** – Especially important because hair and dirt accumulates quickly. A dirty condenser can result in a voided warranty, part failure, product loss, and higher electrical cost.
- **Checking temperature** – Normal range is between - 2-8 degrees.
- **Checking lighting** - Is there a light burnt out, or is there a bigger issue causing a light not to work?

PROPER LOADING AND MERCHANDISING OF PRODUCT

For proper performance of the unit and to avoid product spoilage, follow these instructions

- **DO NOT** Stock the fridge above the load line. this will prevent necessary air circulation.
- **DO NOT** block the return air vent at the front interior of the cooler.

CLEANING THE UNIT

The cooler should be cleaned once a week with power supply disconnected to meet a good standard of hygiene and to keep the freezer attractive as an effective point of purchase display.

- **Interior** - Use only mild non-abrasive liquid cleaner, water and a so cloth for the entire freezer interior. Make sure to wipe off all residue.
- **Exterior** - Use only mild non-abrasive liquid cleaner, water and a so cloth for the painted surfaces and a stainless steel polish and cleaner for the stainless steel surfaces if desired.
- **Glass windows** - Due to the special coating on the glass, use only a mild, non-abrasive liquid cleaner, water, and a soft cloth.

PREVENTING MEAT DISCOLORATION

Exposure to LED lighting may cause meat to discolor. In cases where there may be low product turnover, it is recommended to wrap deli meats in an opaque material such as parchment paper instead of clear plastic.



WARRANTY INFORMATION

ONE YEAR PARTS AND LABOUR WARRANTY:

MTL Technologies, Inc. (“MTL Cool”) warrants that every new MTL Cool refrigerated display cooler, the cabinet, and all parts shall not contain any defects in material or workmanship, under normal and proper use and maintenance service as specified by MTL Cool and upon proper installation and startup in accordance with the instructions provided with each MTL Cool unit. Except as otherwise set forth herein, MTL Cool’s obligation under this warranty is limited to a period of one year from the date of original shipment.

Any parts covered under this warranty that MTL Cool determines to have been defective within the one year Warranty Period is limited to the repair or replacement, including labour charges of defective parts or assemblies. The labour warranty shall include standard straight time labour charges only and reasonable travel time as determined by MTL Cool.

MTL Cool must authorize all labour. All costs not covered under warranty will be the responsibility of the original purchaser.

Our obligation under this warranty shall be limited to repairing or replacing F.O.B. factory any of such products, which proves thus defective which our examination shall disclose to our satisfaction to be defective.

Any part returned to the company under the terms of this warranty must be accompanied by a record of the cabinet model, the MTL Cool serial number located on the back of the unit, and a return authorization number, and such return shall be on the basis of TRANSPORTATION CHARGES PREPAID BY MTL COOL.

Improper operation due to low or high voltage conditions, inadequate wiring, and accidental damage are not manufacturing defects and are strictly the responsibility of the purchaser.

The term “original purchaser” as used herein shall be deemed to mean that person, firm, association of

corporation for whom the Refrigeration Unit referred to herein is originally purchased.

NO CLAIMS CAN BE MADE AGAINST THIS WARRANTY FOR LOSS OF PRODUCT

These warranties are in lieu of all other warranties, expressed or implied, and of all other obligations or liabilities on our part. We neither assume nor authorize any other person to assume for us any other obligation or liability in connection with the sale of said refrigeration units or any part thereof. This warranty shall not be transferred and shall be honoured only in so far as to the original purchaser.

WARRANTY CLAIMS

All claims for labour or parts must be made directly through MTL Cool. All claims should include: model number of the unit, the serial number of the cabinet, proof of purchase, date of installation, and all pertinent information supporting the existence of the alleged defect.

In case of a warranty claim relating to compressors, the compressor model tag must be returned to MTL Cool along with the above listed information.

TRANSPORTATION CLAIMS

In the event parts need to be sent back to MTL Cool, MTL Cool will accept parts under this warranty on the basis of transportation charges prepaid by MTL Cool.

WHAT IS NOT COVERED BY THIS WARRANTY

Except as otherwise set forth herein, MTL Cool’s sole obligation under this warranty is limited to either repair or replacement of parts, subject to the additional limitations below. This warranty neither assumes nor authorizes any person to assume obligations other than those expressly covered by this warranty.

NO CONSEQUENTIAL DAMAGES

MTL Cool is not responsible for economic loss, profit loss, or special, indirect, or consequential damages, including without limitation, losses or damages arising from food or product spoilage claims whether or not on account of

refrigeration failure.

WARRANTY IS NOT TRANSFERABLE

This warranty is not assignable and applies only in favour of the original purchaser / user to whom delivered. Any unauthorized assignment or transfer shall void all warranties, expressed or implied, including all warrant of merchantability or fitness for a particular purpose.

IMPROPER USAGE

MTL Cool assumes no liability for parts or labour coverage for component failure or other damages resulting from improper usage or installation, moving to another location, or failure to clean and/or maintain product as set forth in the warranty packet provided with the unit.

ALTERATION, NEGLIGENCE, ABUSE, MISUSE, ACCIDENT, DAMAGES DURING TRANSIT, INSTALLATION, MOVING TO ANOTHER LOCATION, FIRE, FLOOD, OR ACTS OF GOD

MTL Cool is not responsible for the repair or replacement of any parts that MTL Cool determines have been caused after the date of purchase by alteration, neglect, abuse, misuse, accident, damage during transit or installation, fire flood, or act of God.

IMPROPER ELECTRICAL CONNECTIONS

MTL Cool is not responsible for the repair or replacement of failed or damaged components resulting from electrical power failure, the use of extension cords, low or high voltage, or voltage drops to the unit.

ITEMS THE WARRANTOR WILL NOT PAY FOR

Service calls to correct the installation of your appliance, to instruct you how to use your appliance, to replace or repair fuses or to correct wiring or plumbing.

Service calls to repair or replace appliance light bulbs or broken shelves. Consumable parts (such as filters) are excluded from warranty coverage.

Damage resulting from accident, alteration, misuse, abuse, fire, flood, acts of God, improper installation not in accordance with electrical or plumbing codes, or use of products not approved by warrantor.

Replacement parts or repair labour costs for units operated outside the U.S. or Canada.

Repairs to parts or systems resulting from unauthorized modifications made to the display cooler.

Expenses for travel and transportation for product service in remote locations.

The removal and reinstallation of your display cooler if it is installed in an inaccessible location or is not installed in accordance with published installation instructions.

NO IMPLIED WARRANTY OF MERCHANTABILITY OR FITNESS FOR A PARTICULAR PURPOSE: THERE ARE NO OTHER WARRANTIES, EXPRESSED, IMPLIED OR STATUTORY, EXCEPT THE ONE YEAR PARTS & LABOUR WARRANTY AS DESCRIBED ABOVE. THESE WARRANTIES ARE EXCLUSIVE AND IN LIEU OF ALL OTHER WARRANTIES, INCLUDING IMPLIED WARRANTY AND MERCHANTABILITY OR FITNESS FOR A PARTICULAR PURPOSE. THERE ARE NO WARRANTIES WHICH EXTEND BEYOND THE DESCRIPTION ON THE FACE HEREOF.

OUTSIDE NORTH AMERICA

This warranty does not apply to any warranty claims made on products sold or used outside of the United States and Canada.

LIMITATION OF LIABILITY

MTL Cool or their affiliates shall not be liable for any indirect, incidental, special or consequential damages, or losses of a commercial nature arising out of malfunctioning equipment or its parts or components thereof, as a result of defects in material or workmanship.

THE ORIGINAL OWNER'S SOLE AND EXCLUSIVE REMEDY AND MTL COOL'S SOLE AND EXCLUSIVE LIABILITY SHALL BE LIMITED TO THE REPAIR OR REPLACEMENT OF PARTS OR COMPONENTS CONTAINED IN THE EQUIPMENT IDENTIFIED ABOVE WHICH UNDER NORMAL USE AND SERVICE MALFUNCTION AS A RESULT OF DEFECTS IN MATERIAL OR WORKMANSHIP, SUBJECT TO THE APPLICABLE PROVISIONS AND LIMITATIONS STATED ABOVE.

MTL COOL IS NOT LIABLE FOR ANY DAMAGE OR LAW SUITS RELATED TO WATER LEAKS COMING FROM THE COOLER OR FREEZER. IF A COOLER OR FREEZER IS LEAKING, IMMEDIATELY TURN THE DISPLAY OFF AND UNPLUG IT. CLEAN UP THE WATER AND CALL OUR SERVICE DEPARTMENT AT 1-888-685-8324.

